



## Semarak International Journal of Machine Learning

Journal homepage:  
<https://semarakilmu.my/index.php/sijml/index>  
ISSN: 3030-5241



# Delving into the Revolutionary Impact of Artificial Intelligence on Mechanical Systems: A Review

Hashem F. Shatnawi<sup>1,\*</sup>, Mohammad N. Alqahtani<sup>1</sup>

<sup>1</sup> Royal Commission for Jubail, Education Sector in Jubail, Jubail Technical Institute, Jubail Industrial City, 31961, Saudi Arabia

### ARTICLE INFO

#### Article history:

Received 1 March 2024  
Received in revised form 10 March 2024  
Accepted 24 March 2024  
Available online 27 April 2024

#### Keywords:

Artificial intelligence; autonomous vehicles; mechanical systems; firefighting; heat exchangers; fault detection

### ABSTRACT

Artificial intelligence technology has become a highly advanced field in science and technology, extensively utilized in business and everyday activities. Artificial intelligence is widely used in engineering, especially in the automotive industry, autonomous vehicles, optimizing heat exchangers' operational settings, and assisting firefighters in rescuing victims in low visibility situations. This work examines the applications of artificial intelligence in mechanical systems, particularly focusing on its utilization in automobiles, heat exchangers, safety and fire systems, and other mechanical systems. Artificial intelligence in mechanical systems enhances precision, minimizes inefficiencies, and substantially cuts manufacturing expenses. Consequently, artificial intelligence will enhance mechanical systems, boosting their production and efficiency.

## 1. Introduction

Artificial intelligence (AI) has been utilized in mechanical engineering since the early stages. Initial uses of AI in mechanical engineering were on employing trained and rule-based systems to automate decision-making and problem-solving in production, design, and maintenance. Recent breakthroughs in machine learning and deep learning approaches have been utilized in mechanical engineering to enhance the capabilities and performance of AI-based systems in areas like modeling, optimization, control, and prediction.

Predictive modeling using artificial intelligence (AI) has been an active area of research for several decades. The earliest work on predictive modeling using AI in mechanical engineering started between 1960s and 1970s [1], when researchers began exploring the use of expert systems and rule-based systems to automate decision-making and problem-solving in areas such as manufacturing, design, and maintenance.

In the 1980s and 1990s, researchers began to apply machine learning techniques, including decision trees, neural networks, and support vector machines, to predictive modeling in mechanical

\* Corresponding author.  
E-mail address: [shahem121@yahoo.com](mailto:shahem121@yahoo.com)

engineering [2]. These techniques allowed for the creation of more complex models and the ability to automatically learn from data, rather than relying on expert knowledge.

Many Mechanical systems use artificial intelligence methods [3] shown in Figure 1. Besides AI machine learning is categorized into several forms as shown in Figure 2.

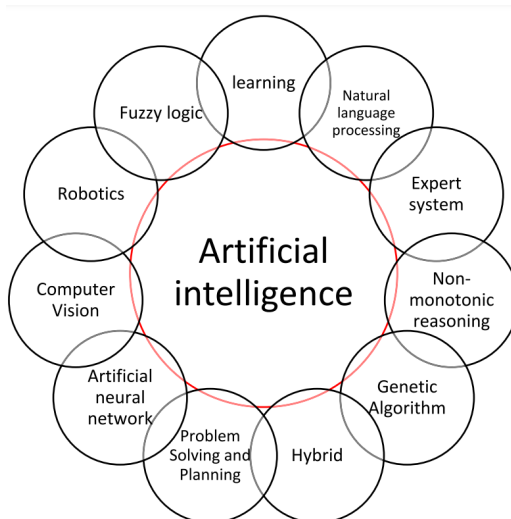

Fig. 1. Artificial intelligence disciplines [3]

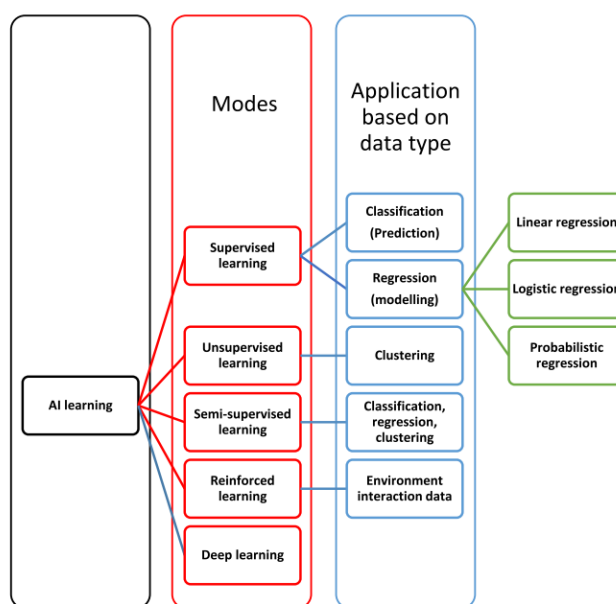

Fig. 2. A categorization method for AI learning algorithms [3]

## 2. AI in the Automotive Industry

Artificial intelligence is frequently portrayed as a novel idea in the automotive sector, due to the growing excitement surrounding self-driving technology. AI, a branch of machine learning or computer algorithms, has existed for a while. It is commonly used to enhance laborious manual activities' accuracy, speed, and scalability. Artificial intelligence trained to identify certain photos and classify them. Besides, AI can be employed in designing to generate novel shapes and patterns [4].

Artificial intelligence can provide significant opportunities for the automotive industry, enhancing manufacturing efficiency and introducing revolutionary automobile models [5]. AI is successfully digitizing and reshaping the automotive sector through numerous methods. It aids in accelerating and improving the process of manufacturing cars by utilizing AI robots that can identify flaws and assemble parts with exceptional precision. This results in a reduction in errors and an increase in the number of cars being produced daily. AI can process large amounts of data to design streamlined, aerodynamic forms that reduce air resistance and fuel consumption. AI is assisting in designing lighter and more efficient wheels. On the other hand, AI can develop methods to create electric fuels (e-fuels) in a more cost-effective and environmentally friendly manner, which could lead to a more sustainable future for automobiles [6]

Toyota observed that the optimization concepts commonly applied in computer-aided engineering may be integrated with text-to-image generative AI as shown in Figure 3. The algorithm would enable incorporating performance, safety, and usability considerations at an early stage of the creative process, with minimal disruption to the overall design aesthetic. Aerodynamic drag, which impacts fuel consumption, and chassis parameters like ride height and passenger accommodation capacity, which influence control, ergonomics, and safety, can now be imbedded in the generative AI procedure. [7]

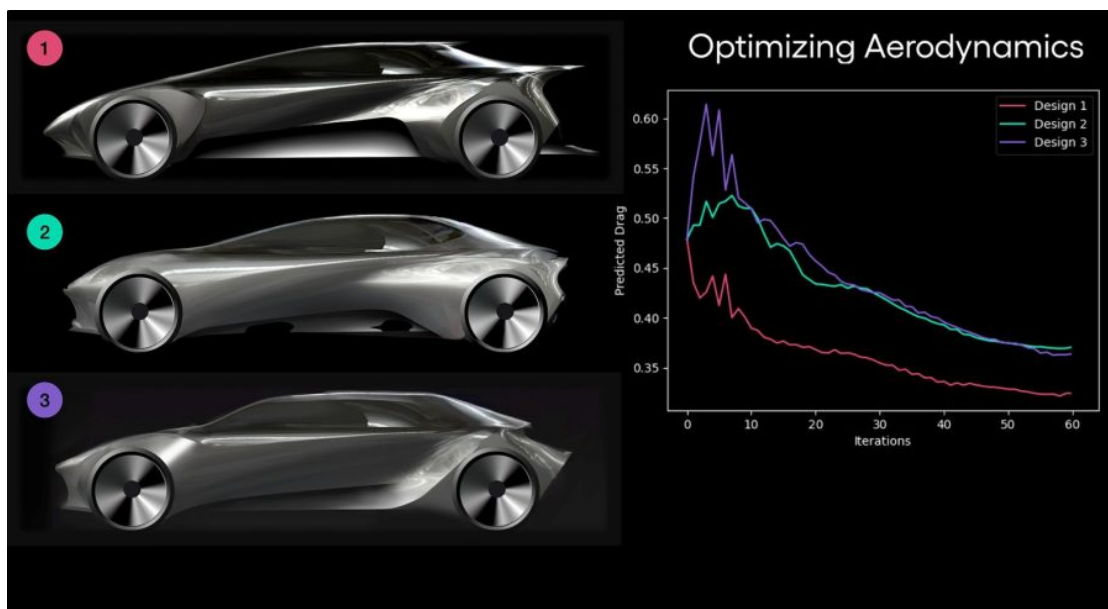

**Fig. 3.** Optimizing aerodynamics of initial prototype sketch using AI [7]

Self-driving automobiles are expected to improve transportation flow and efficiency and have significant economic effects. As per [8], there are six stages of automated vehicles, ranging from level 0 with full driver control to level 5 with full vehicle control of all driving functions. The levels are illustrated in Figure 4.

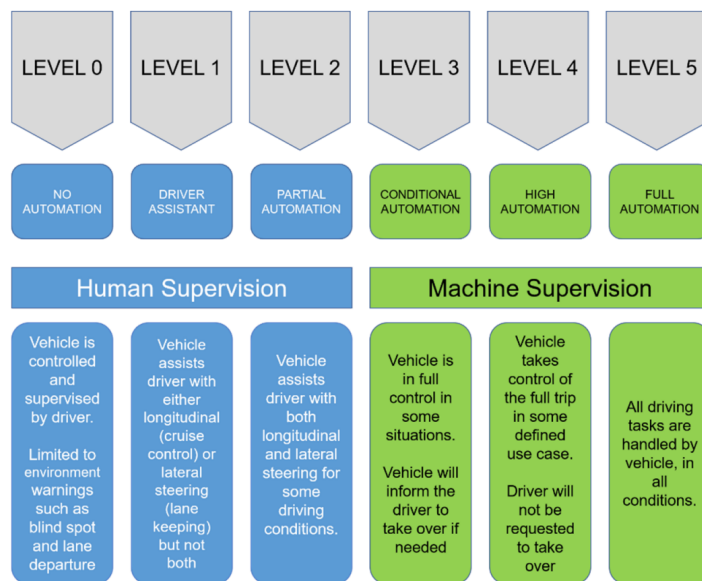

Fig. 4. The Society of Automobile Engineers' classification of autonomous vehicles [8]

Md. Chy [9] created an autonomous product delivery vehicle capable of driving on roads and providing real-time geographical position updates to authorities via a map. The camera transmits a picture and then awaits the steering angle value. The image is inputted into a pre-trained deep-learning model, which forecasts the steering angle based on the circumstances. The steering angle data is transmitted to the Raspberry Pi, which then controls the L298 motor driver to determine the direction in which the wheel should turn. Based on this input, L298 determines the direction of movement to be forward, left, right, or backward.

### 3. AI in the Heat Transfer

Jamal research [10] introduces a model for controlling heat exchanger HE temperature using an AI approach. The controllers utilized in this work are based on artificial intelligence and specifically use a fuzzy logic controller consisting of five layers as illustrated in Figure 5. The controllers utilized are adaptive neuro-fuzzy controllers. The study employed a model that integrated fuzzy logic control with neural network approaches. The findings demonstrate that the fuzzy logic controller effectively stabilizes the temperature of the heat exchangers.

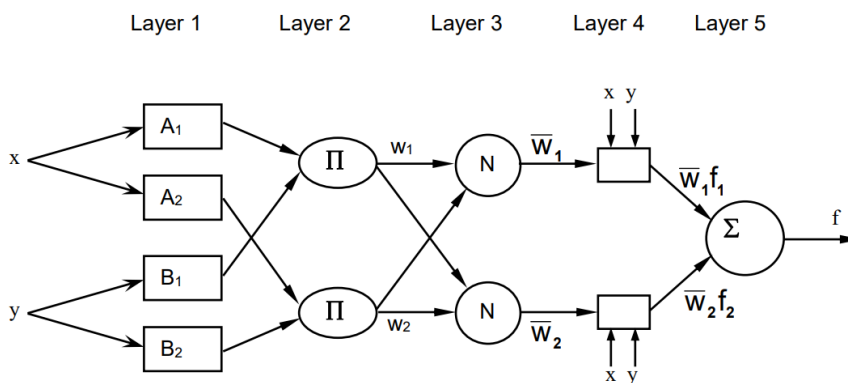
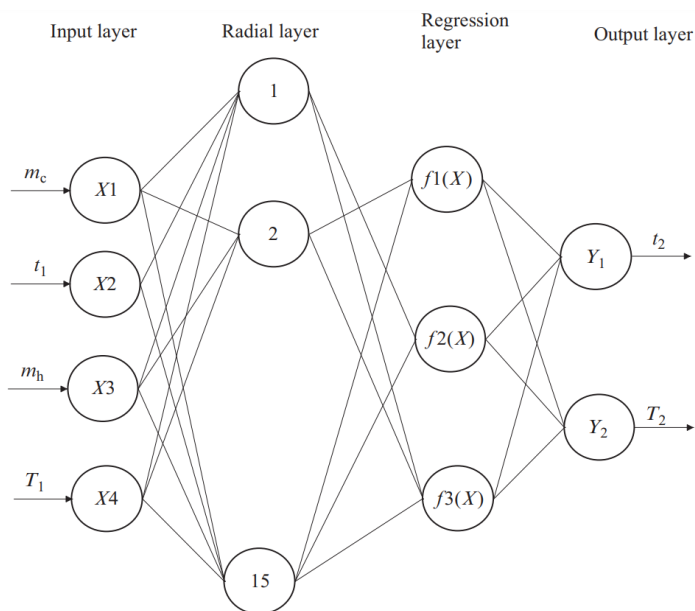

Fig. 5. Neuro-fuzzy architecture based on Sugeno model

Four layers generalized regression neural network model GRNN was used to predict the outlet temperature of a counter-flow heat exchanger [11]. It considered six parameters (four inputs and two outputs): inlet cold fluid rate and temperature, inlet hot fluid rate and temperature, and outlet temperature of cold and hot fluid as seen in Figure 6. The GRNN model can estimate the outlet temperature of hot and cold fluid more accurately than a fuzzy logic-based expert system. It can predict the cold and hot fluid outlet temperature with an accuracy of 96.46% and 98.50% respectively.



**Fig. 6.** Architecture of GRNN used in HE performance study

Jaroslaw [12] devised a thorough method for heat exchanger optimization of the total heat transfer rate of the evaporator by utilizing Artificial Neural Networks and Genetic Algorithms. The technology was shown by employing a huge falling-film evaporator and adsorption desalination-cooling devices. The new technique serves as a supplementary strategy for both design and operational circumstances. As illustrated in Figure 7, The input layer consists of 4 neurons, whereas the output layer consists of 1 neuron. The suggested approach enables us to determine essential parameters associated with both design and operating circumstances.

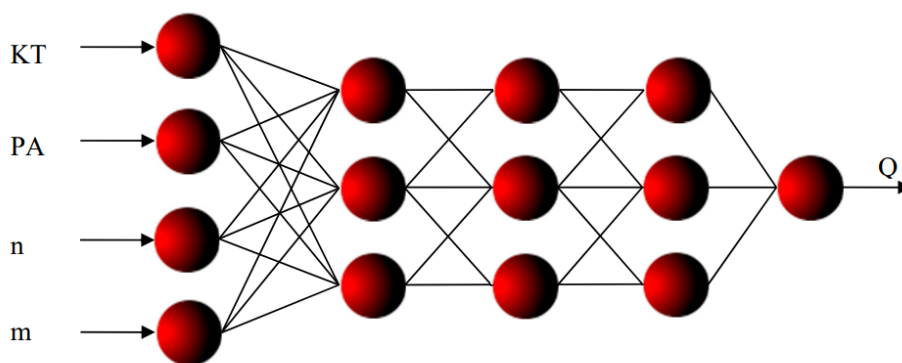

**Fig. 7.** The architecture of the developed AGENN model

A. Khosravi *et al.*, [13] created an intelligent model to predict heat transfer in 5G Smart Poles. The input parameters forecast heat flow and the plate temperature within a utility box. A neuro-fuzzy system which is artificial neural networks (ANNs) in combination with the fuzzy system is used. This fuzzy model is effective with optimization and adaptive approaches. The ANFIS model consists of five layers. An intelligent model was created by combining ANFIS with the particle swarm optimization technique (PSO). Particle PSO is an evolutionary algorithm used to discover the optimal solution for optimization issues. A representation of a basic ANFIS structure with two inputs along with a single output including five layers is shown in Figure 8. The findings indicate that the ANFIS-PSO model accurately predicts the correlation coefficient value (R), with a difference of less than 5% between the theoretical value and the expected value by AI.

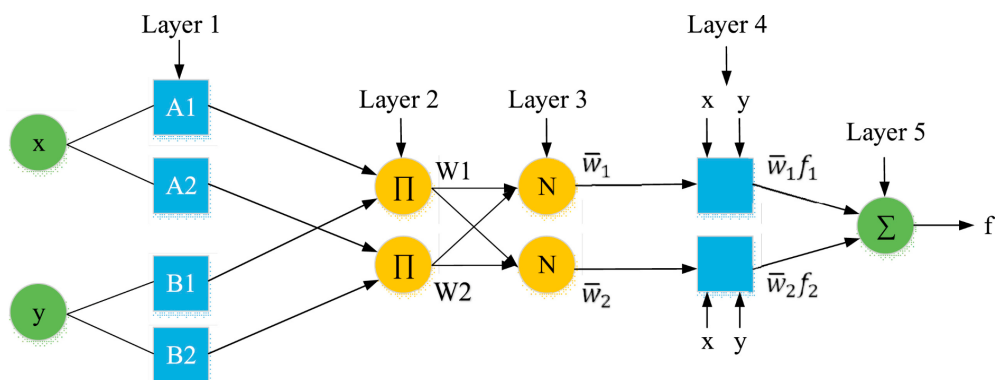

Fig. 8. Five-layer ANFIS model

#### 4. AI in Firefighting

The incorporation of artificial intelligence into fire services has demonstrated positive outcomes in improving firefighting methods in recent times. AI technology provides sophisticated features like data analysis and pattern recognition that may greatly enhance the efficiency of fire control operations. AI is being used significantly in fire prediction and immediate decision-making. AI algorithms have the capability to detect possible fire risks and forecast the propagation and severity of flames. Firefighters may use this information to create preemptive tactics, deploy resources efficiently, and make well-informed judgments in urgent situations. AI-powered devices may offer firefighters real-time data, including building blueprints and occupancy statistics, to improve situational awareness and support firefighting efforts.

Poor visibility frequently presents itself as a challenge for fire officials conducting rescue operations in areas enveloped in smoke and flames. The diminished visibility of objects causes a postponement in the implementation of the rescue operation.

To address this problem, a camera was mounted on the helmet, and basic vision technology was utilized. The camera data is used to improve the fire authorities' vision. The camera's picture frames are sent to a processor to perform basic matrix calculations. The processor will perform edge and contour detection operations utilizing different filters such as a Sobel operator. The processor's output will be shown in the AR glasses the fire officer wears [14]. The image is demonstrated in Figure 9.

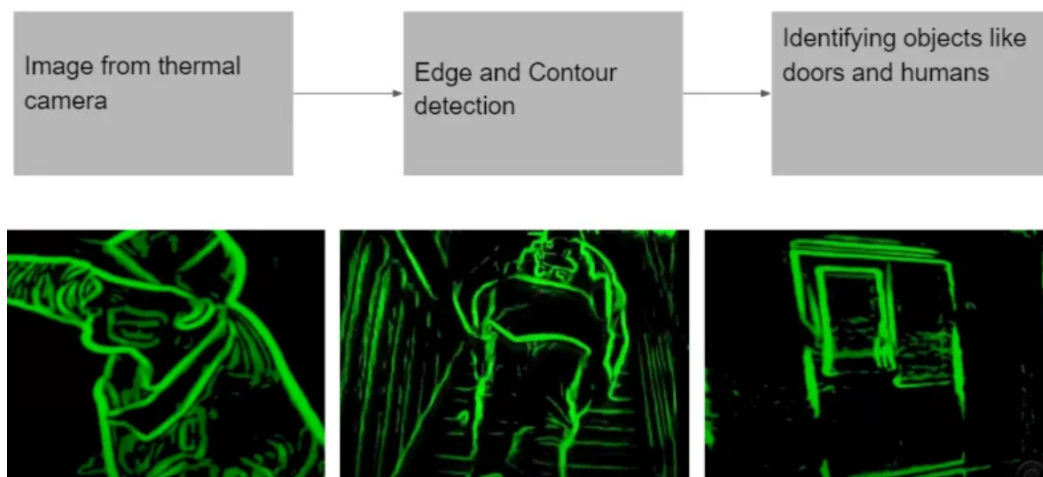

**Fig. 9.** Improved firefighter eyesight with AI

Yanfu Zeng [15] developed an AI program named Intelligent Fire Engineering Tool (IFETool) to accelerate fire safety studies, provide rapid fire assessments, and offer important ideas for enhancements. An extensive numerical fire database is created by analyzing essential structural and fire characteristics. One thousand eighty fire scenarios were simulated with parameters to form a big database for AI mode using Fire Dynamic Simulator software. A model based on deep learning was taught to make 97% accurate predictions regarding the evolution of smoke visibility, temperature, and Carbon monoxide concentration.

Various factors, including wind speed, fire height, wind direction, type of extinguisher, nozzle size, and extinguisher pressure, influence the movement of the fire hose. It is essential to adjust the direction of the fire hose based on these factors, particularly considering wind direction and water pressure adjustments. This can only be accomplished by artificial intelligence, which analyzes factors during a fire and correlates them with the water's speed, direction, and strength.

## 5. AI in HVAC Industry

The HVAC industry is crucial and demands precision, excellence, and reliability. Artificial Intelligence is an optimal method for meeting these requirements through intelligent systems that can function independently, guaranteeing precise and uniform outcomes. AI is utilized in the HVAC sector for design optimization, quality control, predictive maintenance, and energy efficiency. The goal of modeling a system is to understand how it operates under different operating situations. Models are important for establishing the best operating point for a HVAC or cooling system. ANN modeling is the process of training a neural network utilizing data from the system. The dataset consists of input variables that are linked to one or more output variables [16].

The heating or cooling needed to maintain a suitable temperature inside is directly related to the outside temperature, which is constantly changing. The constant flow of people in and out of buildings affects HVAC requirements and comfort levels. All of this requires an intelligent system that uses artificial intelligence to save energy and provide comfort to the user. Chin-Chi C. [17] Built artificial intelligence (AI) tools to enhance the efficiency of (HVAC) systems, with an average energy savings of 14.4%, with AI-assisted control. The most often used AI tools for commercial and residential buildings are Artificial Neural Networks (ANN) and fuzzy tools. The multiple feedback sensor gathers several sensor inputs to create a database, as illustrated in Figure 10.

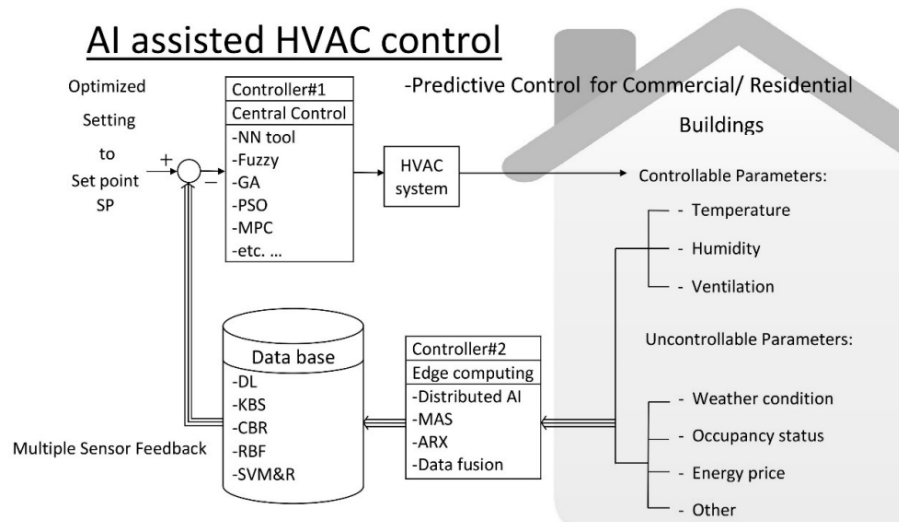

Fig. 10. AI-assisted HVAC controls

Mobarakeh [18] explored the potential of developing an AI algorithm in the shape of a model that can predict the best building heating systems and their optimal performances based on a building's specifications. The models were enhanced by assessing various topologies for the Artificial Neural Networks (ANN) and the implementation of single-objective models. The MOPSO algorithm was utilized to model the data, which included about 194,400 different scenarios. The proposed models' performance was adequate.

## 6. Vibration Fault Detection using AI

Yang [19] presented a leak monitoring system that concurrently detects, localizes, and estimates volume rate in above-ground liquid pipelines. An AI-based leak detection technique reduces leak interpretation mistakes. Pressure gradient intersection is used to locate pipeline leaks using pressure sensors to measure fluid pressure in real time. Accelerometers measure pipeline vibrations in real time, which are used to estimate leak forces using the pipeline's inverse dynamics between the leak and accelerometer locations. The suggested technique achieves 97% accuracy on average.

Ghazali [20] examined the utilization of explainable AI (XAI) algorithms in conjunction with CNNs to monitor vibrations. For classifications based on the Fourier transform and the order analysis of the vibration signal, the three XAI algorithms GradCAM, LRP, and LIME are utilized in conjunction with a modified perturbation strategy. enables an efficient evaluation of saliency values in the presence of variable data periodicity, which corresponds to a real-world machine's fluctuating rotation speed. According to the results, the investigated algorithms are only marginally effective at generating sample-specific saliency maps that are irrelevant or inconsistent.

Lianxiu Li [21] proposes a method for detecting leaks in the urban water supply network through the utilization of ant lion optimization algorithm (ALO) and particle swarm optimization algorithm (PSO). The conduit network is effectively monitored by the water supply network's intelligent monitoring system. Furthermore, the leakage location model of the water supply network is established through the utilization of remote pressure monitoring data, in addition to addressing any leakage detection issues. A pressure-sensitive array, together with a fuzzy clustering technique, has been utilized to organize the pressure monitoring locations in a pipe network. The fuzzy clustering technique or step-by-step assembly approach identifies leak location nodes in various sample locations within the pipe network Figure 11.



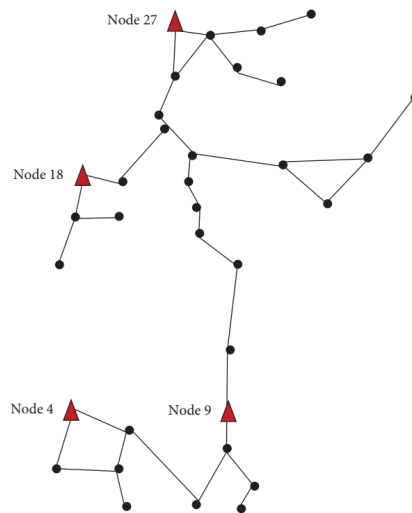

**Fig. 11.** Monitoring pressure points in a pipeline network

#### 4. Conclusions

Artificial intelligence will undoubtedly play a role in several scientific fields, particularly in mechanical systems and equipment. Artificial intelligence not only reduces operating and maintenance expenses and personnel but also plays a crucial role in saving lives and property. Artificial intelligence in automobiles has significantly improved fuel efficiency, safety, and accident prevention. Maximum efficiency may be attained by ensuring the temperature and flow are optimized for peak performance. Utilizing artificial intelligence systems can conserve energy by optimizing air conditioning or heating systems to adapt the temperature for human comfort. Vibrations may be readily monitored and recognized with artificial intelligence systems. The oil sector can also alleviate concerns about oil leaking from pipelines with the help of artificial intelligence.

#### References

- [1] Adelekan, D S, O S Ohunakin, and B S Paul. "Artificial Intelligence Models for Refrigeration, Air Conditioning and Heat Pump Systems." *Energy Reports* 8 (2022): 8451–66.
- [2] Anthony Massobrio. "From Concept to Reality: The Development of an AI-Designed Car." Neural Concept, 2023. <https://www.neuralconcept.com/post/from-concept-to-reality-the-development-of-an-ai-designed-car>.
- [3] Bock, Frederic E, Roland C Aydin, Christian J Cyron, Norbert Huber, Surya R Kalidindi, and Benjamin Klusemann. "A Review of the Application of Machine Learning and Data Mining Approaches in Continuum Materials Mechanics." *Frontiers in Materials* 6 (2019): 110.
- [4] Cheng, Chin-Chi, and Dasheng Lee. "Artificial Intelligence-Assisted Heating Ventilation and Air Conditioning Control and the Unmet Demand for Sensors: Part 1. Problem Formulation and the Hypothesis." *Sensors* 19, no. 5 (2019): 1131.
- [5] Chy, Md Kalim Amzad, Abdul Kadar Muhammad Masum, Kazi Abdullah Mohammad Sayeed, and Md Zia Uddin. "Delicar: A Smart Deep Learning Based Self Driving Product Delivery Car in Perspective of Bangladesh." *Sensors* 22, no. 1 (January 1, 2022). <https://doi.org/10.3390/s22010126>.
- [6] Fayyad, Jamil, Mohammad A. Jaradat, Dominique Gruyer, and Homayoun Najjaran. "Deep Learning Sensor Fusion for Autonomous Vehicle Perception and Localization: A Review." *Sensors (Switzerland)*. MDPI AG, August 1, 2020. <https://doi.org/10.3390/s20154220>.
- [7] Freddie Holmes. "How Is AI Influencing Car Design?" <https://www.carsdesignnews.com/cars/how-is-ai-influencing-car-design/43542.article>, November 11, 2022.

- [8] Ghazali, Mohamad Hazwan Mohd, and Wan Rahiman. "Vibration-Based Fault Detection in Drone Using Artificial Intelligence." *IEEE Sensors Journal* 22, no. 9 (2022): 8439–48.
- [9] Jamal, Agus, and Ramadoni Syahputra. "Heat Exchanger Control Based on Artificial Intelligence Approach." *International Journal of Applied Engineering Research (IJAER)* 11, no. 16 (2016): 9063–69.
- [10] Joe Clifford. "How Toyota Is Using AI to Help Car Designers." *TOYOTA UK MAGAZINE*, September 27, 2023. <https://mag.toyota.co.uk/car-designers-using-ai/>.
- [11] Khosravi, A, T Laukkanen, K Saari, and V Vuorinen. "An Artificial Intelligence Based-Model for Heat Transfer Modeling of 5G Smart Poles." *Case Studies in Thermal Engineering* 28 (2021): 101613.
- [12] Krzywanski, Jaroslaw. "A General Approach in Optimization of Heat Exchangers by Bio-Inspired Artificial Intelligence Methods." *Energies* 12, no. 23 (2019): 4441.
- [13] Kumar, Vedant. "Applications of Artificial Intelligence in Fire & Safety." *Overview of the Applications of AI in Mitigating the Dangers Due to Fire*, 2020.
- [14] Li, Lianxiu, and Huifan Chen. "Artificial Intelligence and Internet of Things-Based Leak Detection Method for the Water Supply Network." *International Transactions on Electrical Energy Systems* 2023 (2023).
- [15] Mckoy, DeQuante Rashon, Raymond Charles Tesiero, Yaa Takyiwaa Acquah, and Balakrishna Gokaraju. "Review of HVAC Systems History and Future Applications." *Energies* 16, no. 17 (2023): 6109.
- [16] Mobarakeh, Jalil Mokhtarian, and Hoseyn Sayyaadi. "A Novel Methodology Based on Artificial Intelligence to Achieve the Formost Buildings' Heating System." *Energy Conversion and Management* 286 (2023): 116958.
- [17] Peter, Norvig, and Russell Stuart Artificial Intelligence. "A Modern Approach." Pearson Education, USA, 2021.
- [18] Priyanka Ankireddy, S Gopalakrishnan S., and V. Lokeswara Reddy. "Automated Recognition and Tracking of Stationary and Moving Cars in Images and Videos: YOLOv5 and SSD Analysis." *Journal of Advanced Research in Applied Sciences and Engineering Technology* 40, no. 2 (February 28, 2024): 221–41. <https://doi.org/10.37934/araset.40.2.221241>.
- [19] Sridharan, M. "Applications of Artificial Intelligence Techniques in Heat Exchanger Systems." In *Advanced Analytic and Control Techniques for Thermal Systems with Heat Exchangers*, 325–34. Elsevier, 2020.
- [20] Yang, Jaehyun, Hamid Mostaghimi, Ron Hugo, and Simon S Park. "Pipeline Leak and Volume Rate Detections through Artificial Intelligence and Vibration Analysis." *Measurement* 187 (2022): 110368.
- [21] Zeng, Yanfu, Xiaoning Zhang, Ling Chu Su, Xiqiang Wu, and Huang Xinyan. "Artificial Intelligence Tool for Fire Safety Design (IFETool): Demonstration in Large Open Spaces." *Case Studies in Thermal Engineering* 40 (December 1, 2022). <https://doi.org/10.1016/j.csite.2022.102483>.